

Technical data sheet  
(Jan. 2018)

# LT 12 RD XP

## Permanent weights

**MiDi**  
C R A N E S



CE

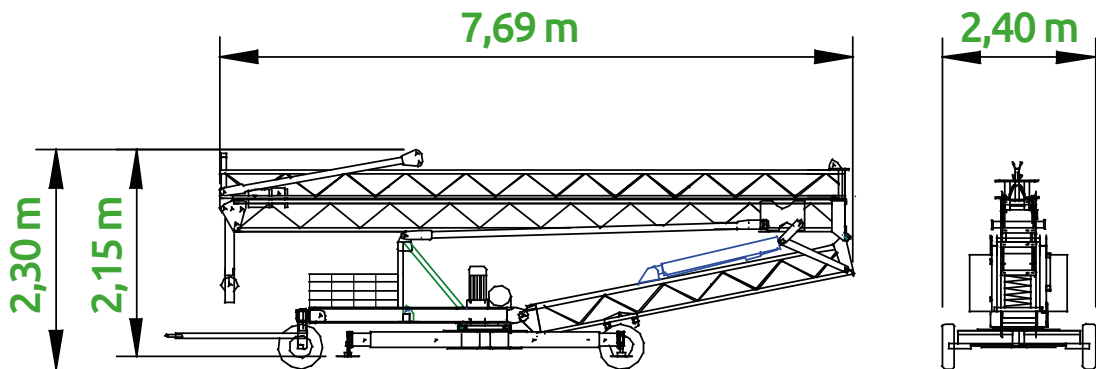
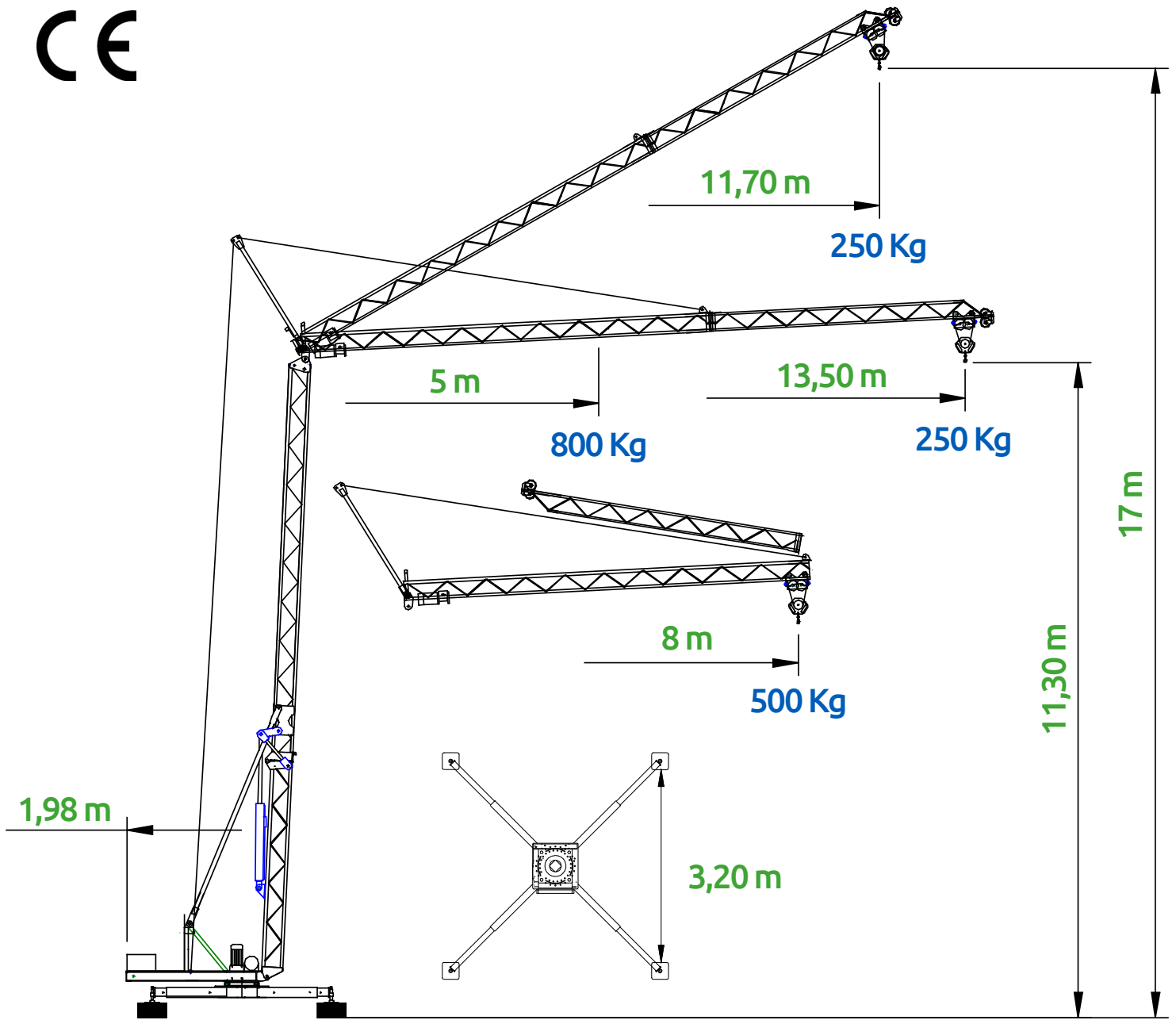

# FAST SELF-ERECTING CRANE MIDI LT 12 RD XP



## ENGINES (220 V)

Elevation	2,0 HP	three-phased
Rotation	0,5 HP	three-phased
Trolley	0,5 HP	single-phased
Hydraulic	1,0 HP	single-phased



MAIN CHARACTERISTICS	HORIZONTAL BOOM	TILTED BOOM (30°)
Electrical voltage - single-phased	220 V	
Required power	2500 W	
Boom / Hook heights	12 / 11,30 m	18 / 17 m
Maximum range	13,50 m	11,70 m
Maximum load at end of the boom	250 Kg	
Maximum load	800 Kg	400 Kg
Range at maximum load	5 m	9 m
Overall weight	3500 Kg	
Counterweights - <b>INCLUDED IN THE STRUCTURE</b> Counterweights are always on the crane, even during transport. It is not necessary to add more counterweights for mounting and working.		
Distance between levelling stabilizers	3,20 m	
Turning radius at base	1,98 m	
Lenght with folded boom	8 m	7 m
Load at end of the boom with folded boom	500 Kg	400 Kg
Electrial cabinet with stop buttons		
Frequency converter for rotation and elevation		
2 elevation speeds	8 mpm - 16 mpm	
Hydraulic mounting for boom and tower		

## LOAD DIAGRAM

RANGE (m)		5	6	7	8	9	10	11,70	12	13,5
Horizontal boom		800	675	-	450	-	350	-	275	250
Tilted boom 30°	<b>Kg</b>	-	-	-	-	400	330	250	-	-
Folded boom		800	690	585	500	-	-	-	-	-

## SAFETY FEATURES

- Maximum load limiter
- Inertia moment limiter
- Trolley travelling limiter
- Hook travelling limiter
- Rotation limiter
- 2nd speed limiter
- Fall-protection device of the trolley with folded boom

# MiDi

C R A N E S

l i f t i n g   e a s y



Z.I N° 3 - 58 route de l'Isle d'Espagnac - B.P. 90553 - 16160 GOND-PONTOUVRE - Tél : 05 45 68 24 33 - Fax : 05 45 69 01 13

Société par actions simplifiée au capital de 150 000 € - R.C.S. ANGOULÊME B 306 216 235 - C.C.P. 2989 32 V BORDEAUX

Z.A Saltgourde - 24430 MARSAC S/ISLE - Tél : 05 53 04 87 22 - Fax : 05 53 04 79 32  
Av. Louis Lumière - Z.I. Périgny 17180 PÉRIGNY - Tél : 05 46 44 48 93 - Fax : 05 46 44 13 24  
8A, rue Georges Claude - Z.A. - 17640 VAUX S/MER - Tél : 05 46 23 95 25 - Fax : 05 46 23 96 11  
122, cours Paul Doumer - 17100 SAINTES - Tél : 05 46 95 06 60 - Fax : 05 46 74 39 11

[www.mazeau.fr](http://www.mazeau.fr)

