

Technical data sheet  
(Jan. 2018)

# LT 14 RD XP **MiDi** Permanent weights C R A N E S

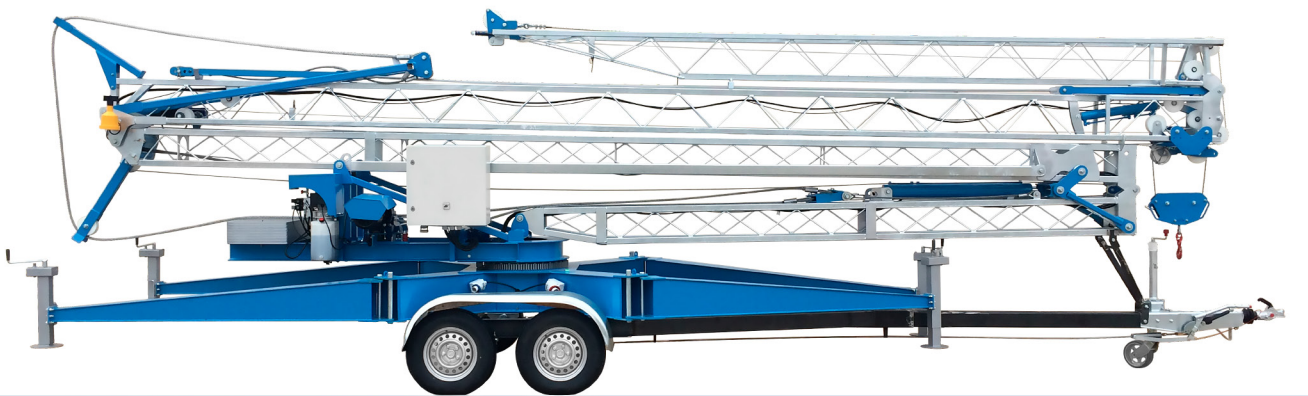

# FAST SELF-ERECTING CRANE MIDI LT 14 RD XP



CE

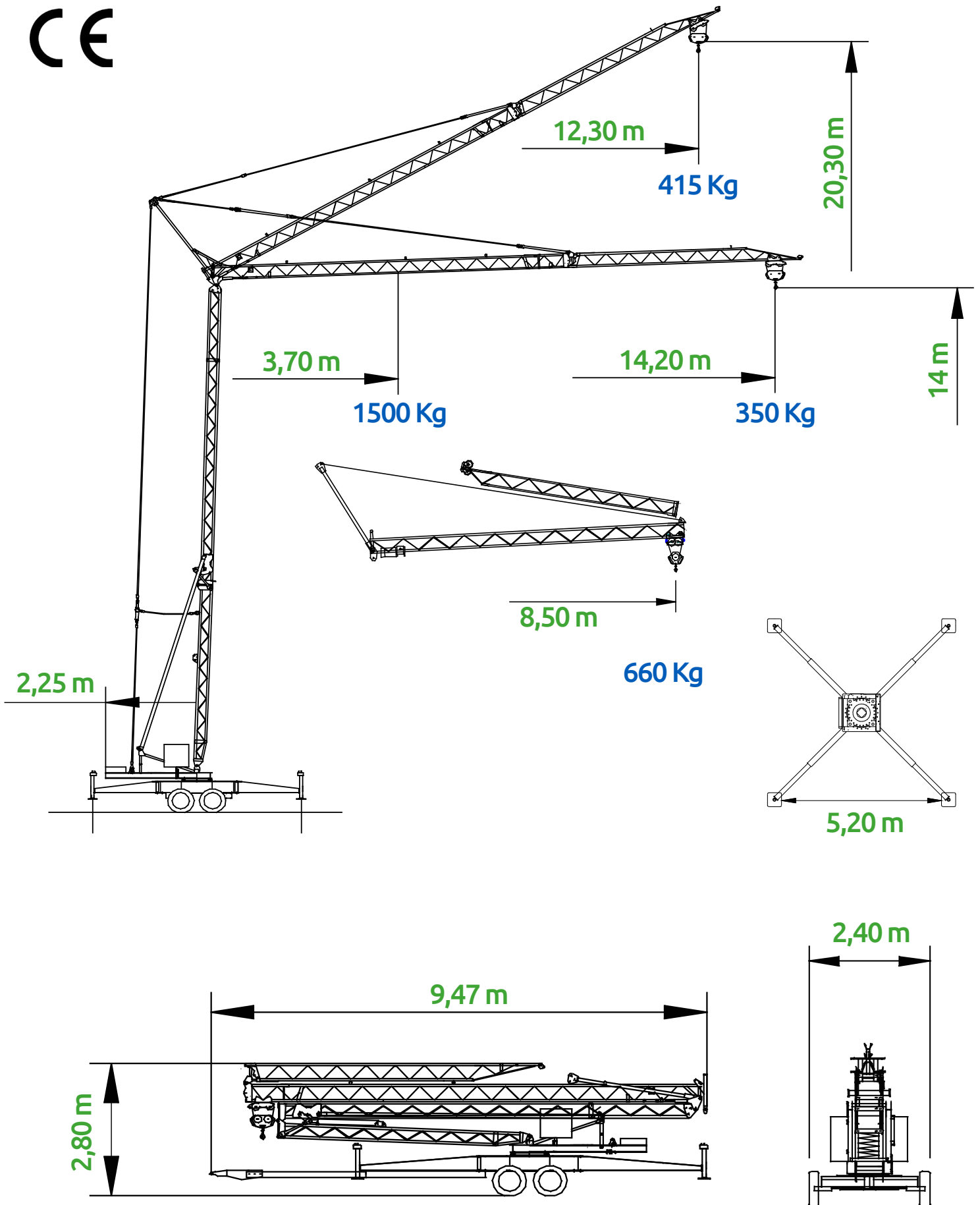

# FAST SELF-ERECTING CRANE MIDI LT 14 RD XP



## ENGINES (220 V)

Elevation	4,0 HP	three-phased
Rotation	0,75 HP	three-phased
Trolley	0,75 HP	three-phased
Hydraulic	1,0 HP	single-phased



## MAIN CHARACTERISTICS

### HORIZONTAL BOOM

### TILTED BOOM (30°)

Electrical voltage - single-phased	230 / 400 V	
Required power	4500 W	
Boom / Hook heights	14,70 / 14 m	21 / 20,30 m
Maximum range	14,20 m	12,30 m
Maximum load at end of the boom	350 Kg	415 Kg
Maximum load	1500 Kg	650 Kg
Range at maximum load	3,70 m	8 m
Overall weight	3500 Kg	
Counterweights - <b>INCLUDED IN THE STRUCTURE, even during transport.</b>		
Distance between levelling stabilizers	5,20 m	
Turning radius at base	2,25m	
Lenght with with folded boom	8,50 m	
Load at end of the boom with folded boom	660 Kg	
Electrial cabinet with stop buttons		
<b>15/15 A</b> : Manoeuvre par automate programmable. Réglage des limiteurs grâce à l'écran tactile		
3 frequency converters for : rotation, elevation, and trolley		
Speeds : 3 elevation (7-12-20 mpm) / 2 rotation (0,3-0,8 mpm) / 2 trolley (8-20 mpm)		
Hydraulique mounting for boom and tower		

## LOAD DIAGRAM

RANGE (m)		3,70	4	5	6	7	8	8,5	10	12	14
Horizontal boom		1500	-	-	875	-	650	-	525	420	350
Tilted boom 30°	<b>Kg</b>	650	-	-	650	-	650	-	535	425	-
Folded boom		-	1500	1220	930	824	-	660	-	-	-

## SAFETY FEATURES

- Maximum load limiter
- Inertia moment limiter
- Trolley travelling limiter
- Hook travelling limiter
- Rotation limiter
- 2nd speed limiter
- Fall-protection device of the trolley with folded boom

# MiDi

C R A N E S

l i f t i n g   e a s y



Z.I N° 3 - 58 route de l'Isle d'Espagnac - B.P. 90553 - 16160 GOND-PONTOUVRE - Tél : 05 45 68 24 33 - Fax : 05 45 69 01 13

Société par actions simplifiée au capital de 150 000 € - R.C.S. ANGOULÊME B 306 216 235 - C.C.P. 2989 32 V BORDEAUX

Z.A Saltgourde - 24430 MARSAC S/ISLE - Tél : 05 53 04 87 22 - Fax : 05 53 04 79 32  
Av. Louis Lumière - Z.I. Périgny 17180 PÉRIGNY - Tél : 05 46 44 48 93 - Fax : 05 46 44 13 24  
8A, rue Georges Claude - Z.A. - 17640 VAUX S/MER - Tél : 05 46 23 95 25 - Fax : 05 46 23 96 11  
122, cours Paul Doumer - 17100 SAINTES - Tél : 05 46 95 06 60 - Fax : 05 46 74 39 11

[www.mazeau.fr](http://www.mazeau.fr)

